

Name:

Class:

Date:

Lesson 7.4: Agricultural Power Tools and Equipment

Lesson Review

Carefully study the lesson and then answer the following questions.

1. What are the six general safety rules for working with power tools? (7.4.0)

Answer:

2. *True or False?* Most power tools have automatic off sensors, so you do not need to unplug them to repair them. (7.4.0)

Answer:

3. *True or False?* Drill presses are similar to handheld power drills. (7.4.1)

Answer:

4. *True or False?* Band saws are used widely in the meat processing industry. (7.4.2)

Answer:

5. All of the following are band saw safety precautions, *except* _____. (7.4.2)

- A. Never place your fingers, hands, or arms in line with the blade
- B. Never stand to the left of the saw while it is in operation
- C. Always wear proper eye protection when using band saws
- D. Make sure the saw blade has been installed properly before using the saw

Answer:

6. *True or False?* Portable power tools have an entirely different set of safety rules from stationary tools. (7.4.3)

Answer:

7. *True or False?* The blade on a circular saw spins counterclockwise. (7.4.3)

Answer:

8. *True or False?* Most portable power tools are safe to be used in wet conditions. (7.4.3)

Answer:

9. Explain how jigsaws and reciprocating saws function. (7.4.3)

Answer:

Match the circular saw components to the correct terms. (7.4.3)

10. Blade

Answer:

11. Blade locking bolt

Answer:

12. Exhaust

Answer:

13. Guard

Answer:

14. Handhold

Answer:

15. Handle

Answer:

16. Power cord

Answer:

17. Shoe or base

Answer:

18. Tilt adjustment

Answer:

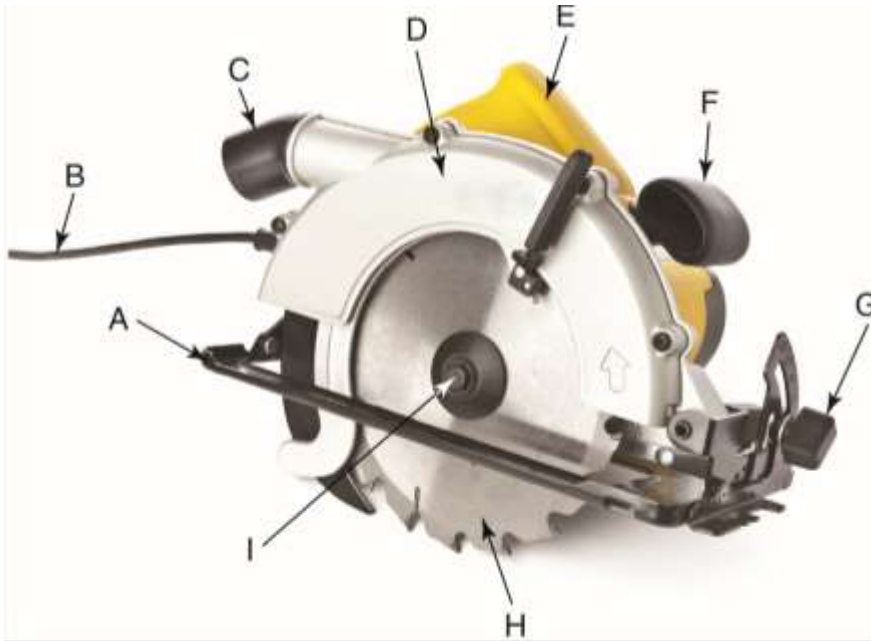

tale/Shutterstock.com

Match the table saw components to the correct terms. (7.4.4)

19. Adjustable leveling feet

Answer:

20. Angle and height adjustment

Answer:

21. Blade

Answer:

22. Blade guard

Answer:

23. Fence

Answer:

24. Power cord

Answer:

25. Table adjustment

Answer:

26. Table

Answer:

27. Table slot

Answer:

28. Telescoping rails

Answer:

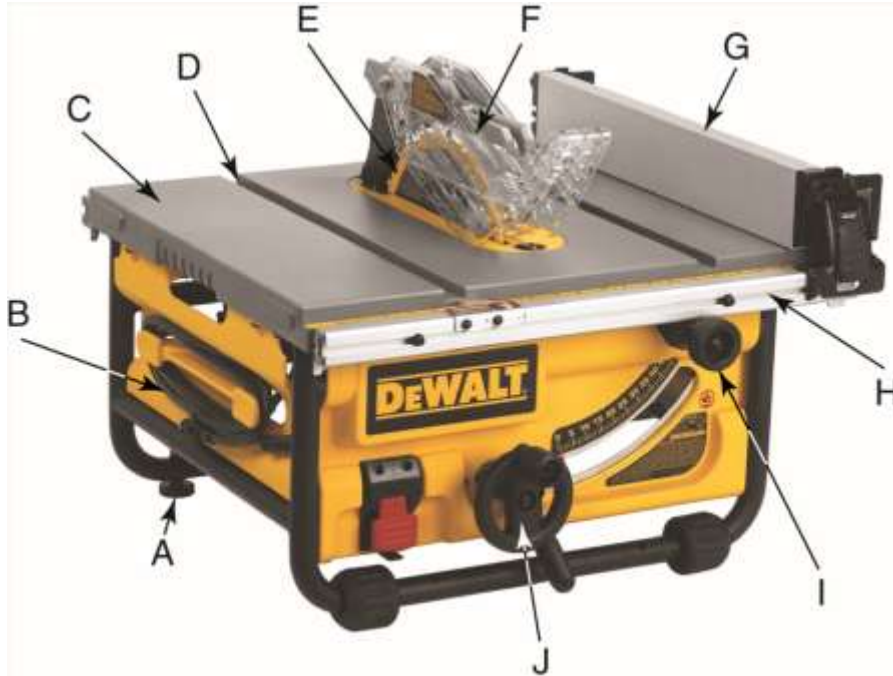

Provided courtesy of DeWALT Industrial Tool Co.

Match the miter saw components to the correct terms. (7.4.4)

29. Blade

Answer:

30. Blade guard

Answer:

31. Dust bag

Answer:

32. Fence

Answer:

33. Fixed blade guard

Answer:

34. Handle

Answer:

35. Miter lock handle

Answer:

36. Miter scale

Answer:

37. Motor

Answer:

38. Table

Answer:

39. Trigger switch

Answer:

40. Turn base

Answer:

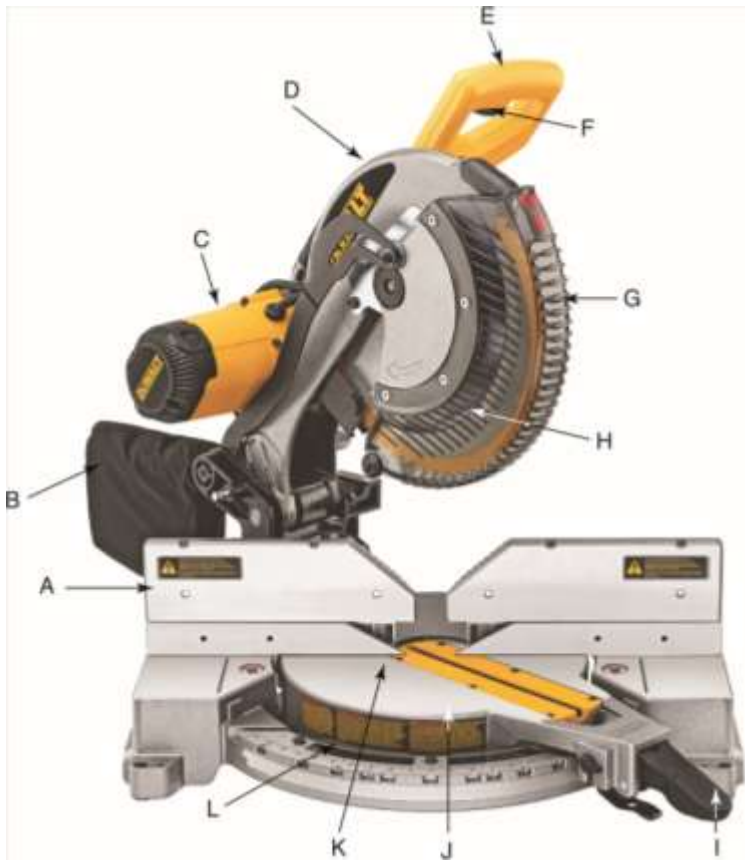

Provided courtesy of DeWALT Industrial Tool Co.

41. *True or False?* Portable power drills are one of the most versatile power tools available. (7.4.3)

Answer:

42. Which power tool uses blades to shape the surfaces and edges of wood stock? (7.4.0)

- A. Reciprocating Saw
- B. Jigsaw
- C. Router
- D. Grinder

Answer:

43. *True or False?* Sanders and grinders have opposite uses: one takes material off, one puts material on. (7.4.3)

Answer:

Match the sander to its description.

- A. Belt-and-disk sander
 - B. Belt sander
 - C. Orbital sander
 - D. Oscillating spindle sander
 - E. Random orbital sander
44. Best used for the initial smoothing of large, flat surfaces (7.4.3)

Answer:

45. Easy to control and mainly used for finish sanding and removing old finish from smaller workpieces (7.4.3)

Answer:

46. A lightweight sander that uses two simultaneous motions (7.4.3)

Answer:

47. A combination stationary sander that is useful for sanding square or curved ends on narrow boards (7.4.3)

Answer:

48. A stationary power sander that uses a spindle that rotates and moves up and down at the same time (7.4.3)

Answer:

49. What are the two basic types of adjustments on a table saw? (7.4.4)

Answer:

50. Explain the difference between a table saw and a radial arm saw. (7.4.4)

Answer:

51. Pneumatic tools use _____ as power to operate. (7.4.5)

- A. propane
- B. specialized fluids
- C. petroleum
- D. compressed gas

Answer:

52. List the two broad categories of petroleum-powered tools. (7.4.6)

Answer:

Critical Thinking

1. As you read through all of the safety tips in this chapter, identify three common safety tips you think should apply regardless of the power tool you are using. (7.4.0)

Answer: